

EVERPURE® E-20 PREFILTER SYSTEM

PREFILTER SYSTEM FOR FOODSERVICE APPLICATIONS

E-20 Prefilter System: EV9795-90
EC210 Prefilter Cartridge: EV9534-26



APPLICATIONS

Foodservice applications
requiring prefiltration
High sediment areas

FEATURES • BENEFITS

Tightly spun EC210 sediment cartridge
delivers 10-micron nominal filtration
20" bowl design accepts most 20" drop
in cartridges
Filters out larger dirt and rust particles.
Extends the life of primary filter cartridges
Durable slim bowl design makes cartridge
change outs easy to handle
Clear housing lets you visually inspect
trapped particles and makes determining
when to change the cartridge easy

INSTALLATION TIPS

Choose a mounting location suitable to
support the full weight of the system
when operating
Make sure to properly lubricate o-ring
prior to use
Use 3/4" water line (optional reducer
bushings included)
Install vertically with bowl hanging down
Allow 2-1/2" (6.35 cm) clearance below the
cartridge for easy cartridge replacement

OPERATION TIPS

Inspect EC210 cartridge periodically to
determine dirt load
Replace EC210 cartridge when dirt has
penetrated through to the inner core of
the cartridge
Do not exceed service flow rate
Inspect o-ring during each cartridge
change. Lubricate and/or replace
if necessary

SIZING

Service Flow Rate: Maximum 6.0 gpm
(22.7 Lpm)

EVERPURE® E-20 PREFILTER SYSTEM

EV9795-90

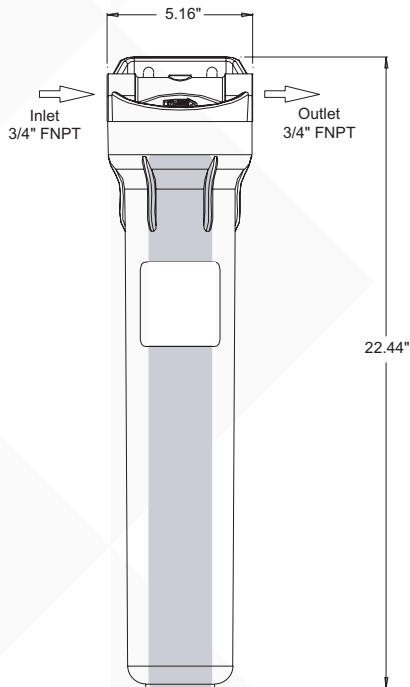

SPECIFICATIONS

Overall Dimensions

22.44" H x 5.16" W x 5.5" D
(56.9 x 13.1 x 13.9 cm)

Connections

Inlet Connection: 3/4"

Outlet Connection: 3/4"

Service Flow Rate

Maximum 6.0 gpm (22.7 Lpm)

Pressure Requirements

10 - 125 psi (0.7 - 8.6 bar), non-shock

Temperature

35 - 100°F (2 - 38°C)

Operating Weight

8 lbs (3.6 kg)

Shipping Weight:

6 lbs (2.7 kg)

Electrical Connection

None required

The contaminants or other substances removed or reduced by this drinking water system are not necessarily in your water. Do not use with water that is microbiologically unsafe or of unknown quality without adequate disinfection before or after the system. Systems certified for cyst reduction may be used with disinfected water that may contain filterable cysts.

WARRANTY

Everpure water treatment systems by Pentair® (excluding replaceable elements) are covered by a limited warranty against defects in material and workmanship for a period of five years after date of purchase. Everpure replaceable elements (filter cartridges and water treatment cartridges) are covered by a limited warranty against defects in material and workmanship for a period of one year after date of purchase. See printed warranty for details. Pentair will provide a copy of the warranty upon request.



FILTRATION & PROCESSING SOLUTIONS

EVERPURE-SHURFLO WORLD HEADQUARTERS, 1040 MUIRFIELD DRIVE, HANOVER PARK, IL 60133 USA • WWW.EVERPURE.COM
800.942.1153 MAIN (US ONLY) • 630.307.3000 MAIN • 630.307.3030 FAX • CSEVERPURE@PENTAIR.COM EMAIL

EVERPURE-SHURFLO AUSTRALIA / NEW ZEALAND, 1-21 MONASH DRIVE, DANDENONG SOUTH, VIC, 3175, AUSTRALIA
1300.576.190 TEL • AU.EVERPURE@PENTAIR.COM EMAIL

EVERPURE-SHURFLO CHINA, 21F CLOUD 9 PLAZA, NO 1118, SHANGHAI, 200052, CHINA
86.21.3211.4588 TEL • 86.21.3211.4580 FAX • CHINA.WATER@PENTAIR.COM EMAIL

EVERPURE-SHURFLO INDIA, GREEN BOULEVARD, B-9/A, 7TH FLOOR - TOWER B SECTOR 62, NOIDA - 201301
91.120.419.9444 TEL • 91.120.419.9400 FAX • INDIACUSTOMER@PENTAIR.COM EMAIL

EVERPURE-SHURFLO EUROPE, PENTAIR WATER BELGIUM BVBA, INDUSTRIEPARK WOLFSTEE, TOEKOMSTLAAN, 30 B-2200 HERENTALS, BELGIUM
+32.(0).14.283.500 TEL • +32.(0).14.283.505 FAX • SALES@EVERPURE-EUROPE.COM EMAIL

EVERPURE-SHURFLO JAPAN INC., HASHIMOTO MN BLDG. 7F, 3-25-1 HASHIMOTO, MIDORI-KU, SAGAMIHARA-SHI KANAGAWA 252-0143, JAPAN
81.(0)42.775.3011 TEL • 81.(0)42.775.3015 FAX • INFO@EVERPURE.CO.JP EMAIL

EVERPURE-SHURFLO SOUTHEAST ASIA, 390 HAVELOCK ROAD, #04-01, KING'S CENTRE, SINGAPORE 169662
65.6795.2213 TEL • FAX: 65.6795.2219 FAX • CSEVERPURE@PENTAIR.COM EMAIL

All Pentair trademarks and logos are owned by Pentair, Inc. All other brand or product names are trademarks or registered marks of their respective owners. Because we are continuously improving our products and services, Pentair reserves the right to change specifications without prior notice. Pentair is an equal opportunity employer.